



LY INTERNATIONAL ELECTRONICS

MULTI-ROOM MUSIC SYSTEM HS-6816

User's Manual

Multi-room Music System HS-6816



HS-3402

Speaker

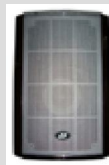

HS-3402

Speaker



Remote Control Pad HS-60R



IR Remote Controller
HS-21



Thank you for using our multi-room music system. For better use of the system, please carefully read this manual before using the equipment.

<http://www.lyintlcorp.com>

Contents

※ Overview	1
1. About Multi-room Music System HS-6816	1
2. Features of The System	1
※ Functions of The System.....	3
1. Functions of Front Panel	3
2. Functions of Rear Panel	5
※ Wiring Diagram of the System.....	6
1. Example of The System Wiring.....	6
Diagram for making a network cable connector.....	6
2. Typical Example of Room Controller Wiring	7
※ Operation of The System	8
1. Status upon Turning on the The System.....	8
2. Manual Operation of a Zone.....	8
3. Manual Operation of MP3 Player.....	9
3.1 Mode selection.....	9
3.2 Time display	9
3.3 Track selection.....	9
4. Manual Operation of Tuner	10
4.1 Band selection.....	10
4.2 Tuning.....	10
4.3 Storage of station	10
4.4 Mute mode	10
4.5 Calling a station	10
5. Timer Programming	11
5.1 Timer setting.....	11
5.2 Time setting	13
5.3 IR teaching.....	14
5.4 Copy schedule.....	14
5.5 System setting.....	15

5.6	Operation of talk.....	15
※	Functions of IR Remote Controller.....	16
※	Application of File Format of USB Disk.....	18
※	Precautions.....	20
1.	Safety Precautions.....	20
2.	After-sales Service Precautions.....	20
※	Packing List.....	21
※	Specifications.....	22
1.	MP3 Player.....	22
2.	AM/FM Tuner.....	22
3.	Timer.....	22
4.	Comprehensive Specifications.....	23

※ Overview

1. About Multi-room Music System HS-6816

HS-6816 is an ideal, state-of-the-art Multi-room Music System, which not only has all basic functions of a traditional home audio system, but also has the following functions. **A. Timing function, which presets specific task executed at certain time:** For example, alert is set to notify you that you should get up on time in the morning; fresh and pleasing background music can be listened to when you are home after a day of busy work; fixed-time news can be listened to, just in the room in which you are staying while listening to the background music. All these only take several minutes to preset in the system that will automatically execute as preset. **B. Different music for different rooms:** For example, due to the difference of interests in music between the elders and teenagers, traditional opera can be listened in the room of the elders, pop music can be listened on in the room of the teenagers, TV can be watched in the living room, and TV programs can be listened to in the kitchen or washing room. All these can be realized as desired. **C. Talk function, through which you can give a talk with other rooms in any room:** For example, by this function, all families can be notified that dinner is ready, so that there is no need to call everyone in every room or speak loudly.

In addition, the operation status of the system is controllable in a room. For example, the program played by the system can be selected by a room controller, and the volume and tone for the room can be controlled.

The console of the system integrates with MP3 player, tuner, zone controller, timer, pre- and post-amplifiers, and accommodates DVD, PC, TV and AUX audio input interfaces, zone 1 and 2 line output interfaces, and zone 3 interface (for controller of all rooms), which facilitates the operation by interactive control between the user and the system.

2. Features of System

- **A feature-packed, state-of-the-art audio system.**
- **Built-in MP3 player and tuner.**
- **A talk can be given between rooms.**
- **With double USB interfaces, supports. MP3 files stored in a common USB disk, MP3 player, mobile HDD, card reader, etc.**
- **FM/AM tuner.**
- **Accommodates DVD, PC, TV and AUX audio input interfaces, and zone 1 and 2 line output interfaces, which utilize RCA connectors.**
- **Integrates with 6 individual stereo output interfaces, for connection to up to 32 room**

controllers of 2 zones of which volume and tone are operable individually.

- **Different audio sources are selectable simultaneously for each room controller and 2 zones.**
- **Controllable through the system and remote control.**
- **Features teaching control of DVD and TV IR remote controllers.**
- **2 built-in audio sources can operate and play at scheduled time, and up to 4 external sources can be set as the source for up to 100 schedules per day. Schedules repeat by week.**
- **The starting time of a timer reaches accuracy level of a second.**
- **One 220V timer control output power is available for external audio sources.**

※ Functions of System

1. Functions of Front Panel

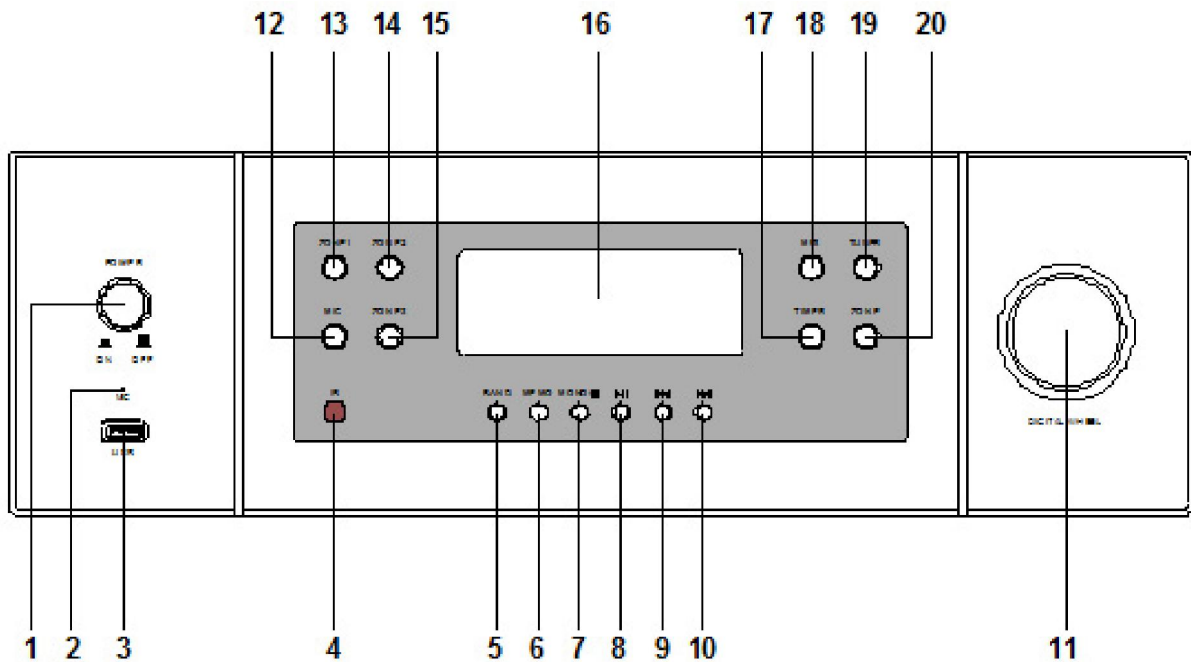

- 1) Power switch: Press down the button to turn on the power, and release the button to turn off the power. The blue indicator around the power switch is indicated when the power is on.
- 2) MIC pick-up: Opening for microphone pick-up.
- 3) USB interface: Connects to a USB disk, mobile HDD or card reader.
- 4) Remote control receiver: Receiver of IR remote control signal.
- 5) Tuner AM/FM switchover key.
- 6) Tuner station memory key.
- 7) Tuner mono/stereo switchover key or MP3 stop key.
- 8) Tuner mute key or MP3 pause/play key.
- 9) Select the next stored station in tuner mode, or select the next track in MP3 mode.
- 10) Select the previous stored station in tuner mode, or select the previous track in MP3 mode.
- 11) Digital wheel: Initiates tuning by frequency in tuner mode; initiates a search for a track and selects a track to play in MP3 mode; highlights an item, selects an item to operate and confirm the operation in timer setting; selects to access a zone control interface, and performs operation and confirm the operation in zone control mode.

- 12) MIC key: Press the key to initiates a talk.
- 13) Zone 1 on/off key.
- 14) Zone 2 on/off key.
- 15) Zone 3 key: Press the key to access centralized control interface for centralized control of all room controllers.
- 16) Display: Shows the operation status and setting interface of the system.
- 17) System and timer setting key: Press the key to access the system setting menu, including various system settings and timer settings.
- 18) MP3 setting key: Press the key to access the MP3 setting interface.
- 19) Tuner setting key: Press the key to access the tuner setting interface.
- 20) Zone setting key: Press the key when the display shows any interface to return to the standby interface, where zone 1 or 2 control interface can be accessed by press the digital wheel.

Switching between operation interfaces:

Function operation interface can be switched over by pressing a function key on the front panel when the primary menu (interface) is shown. For example, press the “MP3” key on the front panel when the tuner status interface is shown, and the tuner status interface will be switched to the MP3 status interface for operation of MP3 status; press the “TIMER” key to access the system and timer setting interface; press the “ZONE” key or one of the zone keys to access the zone status control interface (or standby interface). Interfaces which can be directly switched to are as shown below.

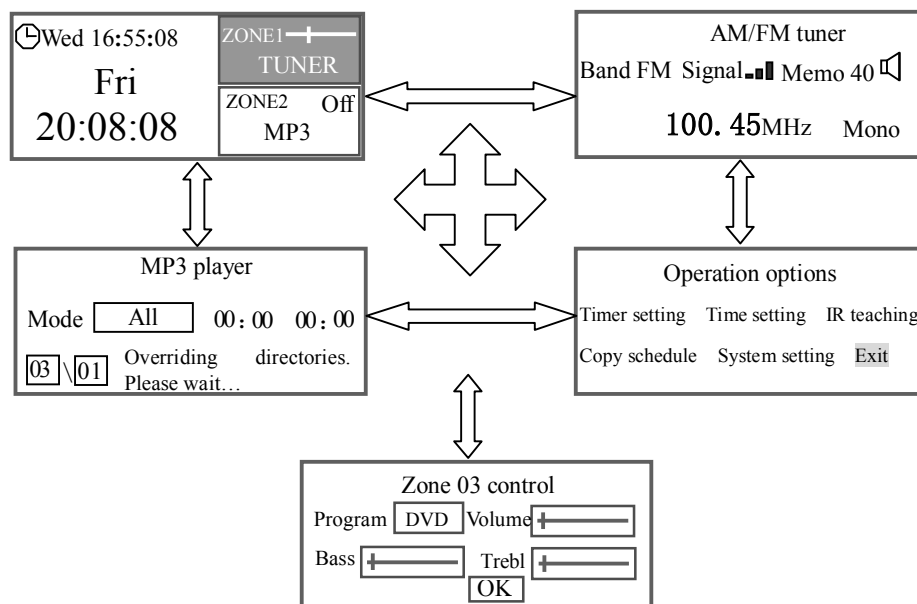

2. Functions of Rear Panel

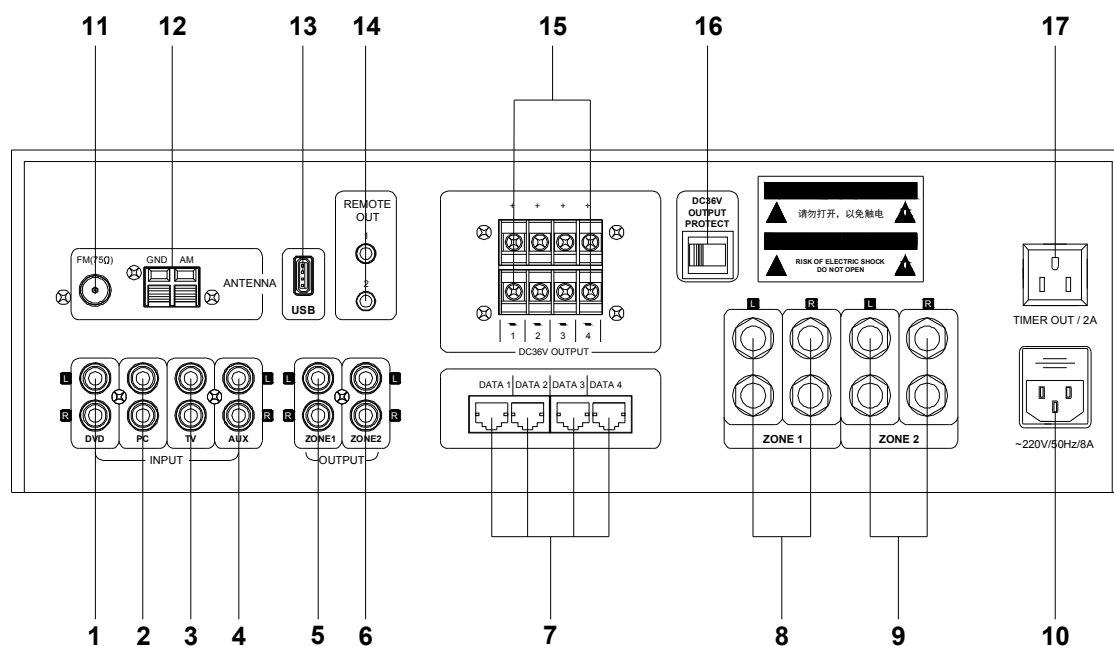

- 1) DVD audio input interface: Connects to a DVD player.
- 2) PC audio input interface: Connects to a PC player.
- 3) TV audio input interface: Connects to audio output interface of a TV.
- 4) AUX audio input interface: Connects to an audio source outputting satisfactory signal levels.
- 5) Zone 1 audio signal line output interface: Outputs zone 1 audio signals, and can be connected to a power amplifier for power scaling.
- 6) Zone 2 audio signal line output interface: Outputs zone 2 audio signals, and can be connected to a power amplifier for power scaling.
- 7) Data output interface: Connects to a room controller with a CAT-5 cable.
- 8) Zone 1 audio power output interface: Connects to a speaker. Do not reverse polarity.
- 9) Zone 2 audio power output interface: Connects to a speaker. Do not reverse polarity.
- 10) AC220V power input interface: Connect the interface with the power cord before connecting the system to the mains.
- 11) FM antenna interface: With an impedance of 75Ω, connects to the provided FM antenna or to a cable TV network.
- 12) AM antenna interface: Connects to the provided AM antenna.
- 13) USB interface: Connects to a USB disk, mobile HDD or card reader.
- 14) Remote control output interface: Controls a DVD player or TV connected.
- 15) DC power output interface: Supplies power to a room controller.
- 16) Room controller power output protection switch: Automatically turns off the DC power output in case of a short circuit of output power supply. To restore the system, reset the switch manually.
- 17) Timer power output socket.

※ Wiring Diagram of the System

1. Example of System Wiring

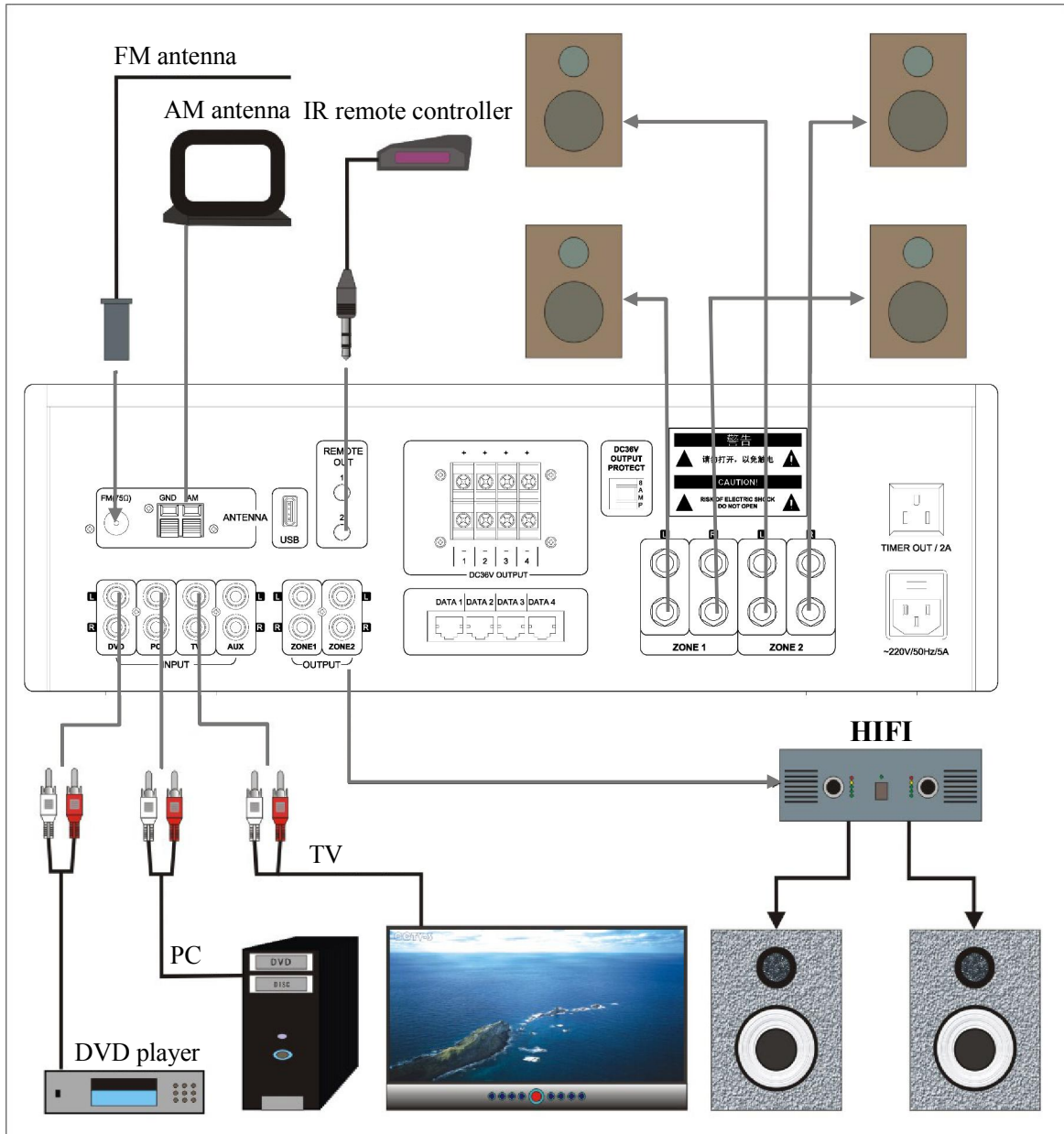
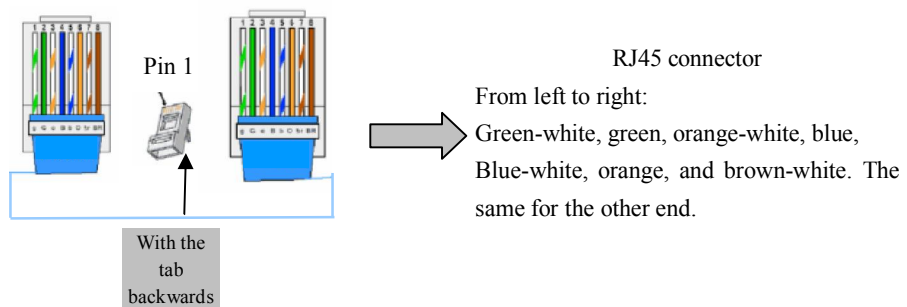
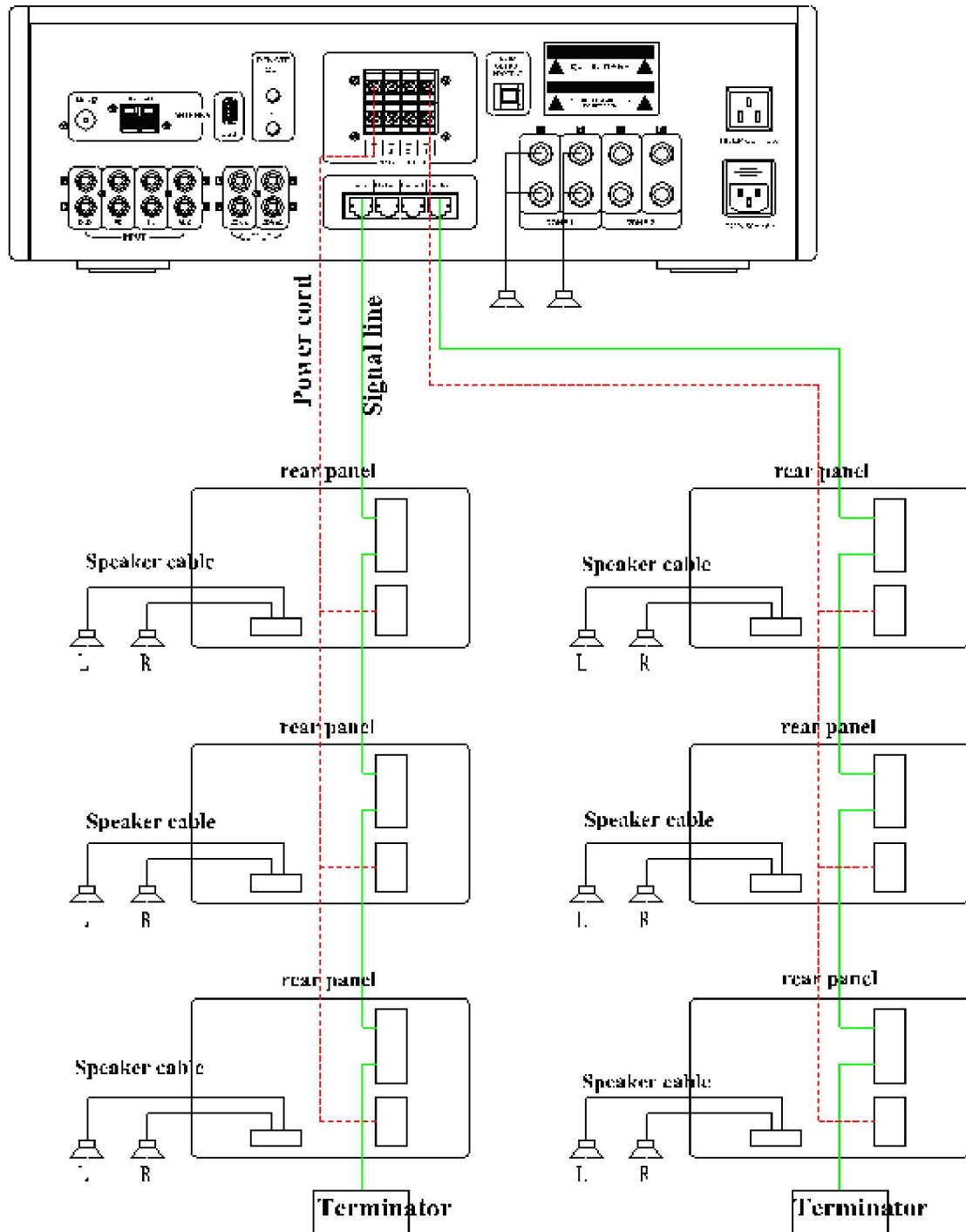

Diagram for making a network cable connector



2. Typical Example of Room Controller Wiring



The last room controller of each channel should be connected with a terminator.

The last room controller of each channel should be connected with a terminator.

Note: Through 4 output channels DATA1 to DATA4, up to 8 room controllers can be connected in the form of “hand in hand” connection, and the length of a signal line of any channel should be less than 150m.

※ Operation of System

1. Status upon Turning on the System

Connect the system according to the wiring diagram and turn on the power supply, and the power indicator will turn on. If no zone is turned on after the system is turned on, the system will be in standby status and the display will show the standby interface (as shown in Fig. 1-1), where if the digital wheel is turned or a zone or source key is pressed down, the corresponding operation interface or the one as shown in Fig. 1-2 will be accessed.

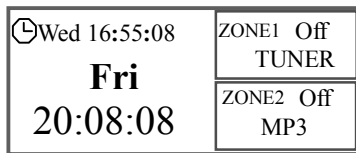

(Fig. 1-1)

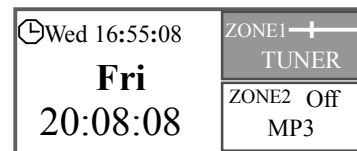

(Fig. 1-2)

2. Manual Operation of a Zone

Operation of a zone includes control of a zone switch, selection of an audio source, and adjustment of volume and tone. Procedure of operation is as follows:

- Access to zone operation interface: Select a zone by turning the digital wheel when the main interface is shown (as shown in Fig. 2-1), and then press down the digital wheel once to access the zone control interface (as shown in Fig. 2-2) where above-mentioned setting can be performed.
- Selection of an audio source: Turn the digital wheel to highlight (i.e. the item is highlighted by the cursor) the content in the box following the “Program” and press down the wheel once, and a  icon will be shown. Turn the wheel again to show up to 6 audio sources successively. In case that the source desired is highlighted, stop turning the wheel, and press down the wheel again to assign the highlighted source to the zone.
- Adjustment of volume: Turn the digital wheel to highlight the content in the box following the “Volume”, and press down the wheel once. Turn the wheel clockwise or counterclockwise to move the slider leftwards or rightwards for adjustment of zone volume. The bass and treble can be adjusted in the same way.
- To end the operation above, turn the digital wheel to highlight the “OK” button, and press it once to apply and exit.

Operation for other zones can be performed in the same way.

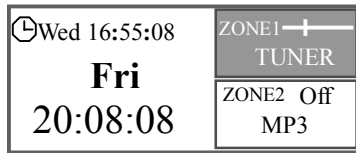

(Fig. 2-1)

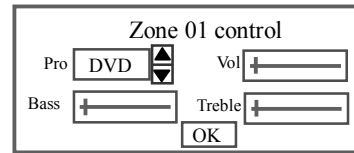

(Fig. 2-2)

3. Manual Operation of MP3 Player

Press the “MP3” key on the panel to access MP3 player control interface (as shown in Fig. 3-1 in the next page).

3.1 Mode selection

This option is used to set the play mode of MP3 player, including “All”, “Single” and “Repeat single”. All music files stored in the player will be played successively in the “All” mode, only the track currently selected will be played in the “Single” mode, and only the track currently selected will be repeated in the “Repeat single” mode.

Operation of setting: Turn the digital wheel to highlight the content in the box following the “Mode”, and then press down the wheel to show the  icon. Turn the wheel to select, and press it again to apply and exit.

3.2 Time display

As shown in Fig. 3-1, the preceding time 00:00 is the play time elapsed of the track currently played, and the one following is the total play time of the track currently played.

3.3 Track selection

As shown in Fig. 3-1, highlight the “03 \ 01” box, press and turn the digital wheel to select. Digits in the preceding box refer to the directory, e.g. “03” means that the 3rd directory of the USB disk is selected. Digits in the following box refer to the number of a track in the directory. The track name is shown following these boxes. In case that the text “No USB disk exists. Please connect a USB disk.” is shown on the lower part of the display, no USB disk is connected to the USB interface or an unidentifiable USB disk is connected. In case that the text “A USB disk is connected. Please wait...” is shown, a USB disk is connected, and the system can access the disk. In case that no track exists in the directory selected, the text “No track exists in the directory. Please select other directory.” is shown, then another directory is accessed and the name of a track in the directory is shown automatically.

Press other function key to exit from the MP3 setting interface after setting.

When manually operating MP3, press the “◀◀” or “▶▶” key on the panel to select a track, press the “▶||” key to play or pause. Also, this can be performed by a line or IR remote controller. For details, refer to functions of the key in this manual.

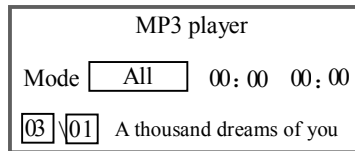

(Fig. 3-1)

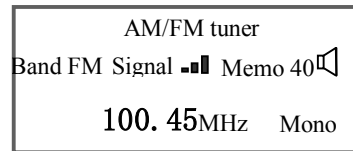

(Fig. 4-1)

4. Manual Operation of Tuner

Press the “TUNER” key to access the tuner control interface (as shown in Fig. 4-1), where the band, station and mono/stereo can be set.

4.1 Band selection

Press the “BAND” key to switch between AM and FM bands. Also, this can be performed by a line or IR remote controller. The frequency range of AM band is 522–1620 kHz, and 87.00–108.00 MHz for FM band.

4.2 Tuning

Press the “◀◀” or “▶▶” key on the panel select a station stored. Turn the digital wheel for tuning by frequency. Turn the wheel clockwise to tune to a higher frequency, or turn it counterclockwise to tune to a lower frequency. In case that a station is tuned in to, signal bar indicator as shown in Fig. 4-1 is shown. More bars will be shown if the signal is strong.

4.3 Storage of station

In case that a station is tuned in to, press the “MEMO” key in combination with the “◀◀” or “▶▶” key to store the station as the storage number successively or randomly. Up to 40 station numbers are available. To store a station, press the “MEMO” key once, and the storage number following the “MEMO” option on the display will flash. Press the “◀◀” or “▶▶” key to adjust the number, and then press the “MEMO” key again to store the station.

4.4 Mute mode

Press the “▶||” key on the panel, and the “🔊” icon will turn into the “🔊/X” icon (as shown in Fig.4-2) indicating that the system is in mute mode. The preset timer is executed at the scheduled time. Press the “▶||” key again to exit from the mute mode.

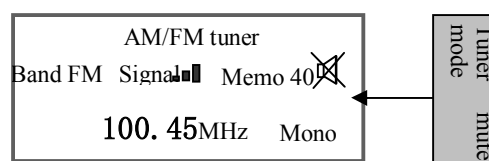

(Fig. 4-2)

4.5 Calling a station

- A stored station can be called at the scheduled time. For details, refer to timer setting.

- A stored station can be directly called by a line or IR remote controller. For details, refer to functions of remote controller keys.

5. Timer Programming

Press the “TIMER” key on the panel to access system setting status, and the display will show the “Operation options” interface (as shown in Fig. 5-1 in the next page), where options like timer setting, time setting, IR teaching, copy schedule, and system setting can be selected.

5.1 Timer setting

Turn the digital wheel to highlight the “Timer setting” option, and press it again to access the timer setting interface (as shown in Fig. 5-1-1 in the next page). Turn the wheel to select an option in the timer setting interface for operation.

5.1.1 Weekday setting:

Turn the digital wheel to highlight the “Weekday” option and press it again, and a  icon will be shown. Turn the wheel to select a weekday (e.g. Wed), and press it again to apply and exit.

5.1.2 New schedule:

When the weekday in the “Weekday” option is set as a weekday (e.g. Mon), all information of the first schedule of the day will be shown in the other options of the interface. In case that other options shows nothing (as shown in Fig. 5-1-2) (**Next page**), no schedule is set for this day. To create a schedule, select the “New” option and set other options of the new schedule. The new schedule is always assigned to the last schedule number of the day. However, schedules are executed according to their set time.

5.1.3 Number setting:

Turn the digital wheel to highlight the content in the box following the “No.”, and then press down the wheel once to show the  icon. Turn the wheel to select, and press it again to apply and exit.



5.1.4 Power setting:

This option is used for timing of power output socket on the rear panel (as described in item 17 in page 4), which supplies power AC220V to other devices. In case that the power setting is set as “On”, power is supplied from the socket at the scheduled time; in case that it is set as “Off”, no power is supplied from the socket at the scheduled time; in case that it is set as “...”, the default setting (i.e. the previous setting) applies. Setting can be done in the same way as the “No.” setting.

5.1.5 Time setting:

This option is used to set the starting time of a schedule, which is accurate to a second and uses 24-hour system. Setting can be done in the same way as the “No.” setting.

5.1.6 Setting of scheduled MP3 tracks

- Turn the digital wheel to highlight the “MP3 setting” option, and press down the wheel once to access the “MP3 timer setting” interface (as shown in Fig. 5-1-3), where up to 3 tracks can be applied to a schedule. The “00/00” refers to the track played, where the first two digits refer to the directory where the track is, and the later two digits refer to the number of the track in the directory. If the directory is set as “00”, no directory is selected. If the track number is set as “00”, no track is selected.
- Selection of track: Turn the digital wheel to highlight the box showing digits, and then press down the wheel once to show the  icon. Turn the wheel to select the directory or track number, and press it again to apply and exit.
- Selection of repetition: Turn the digital wheel to highlight the content in the box following the “Repeat”, and then press down the wheel to show the  icon. Turn the wheel to select “Off”, “Repeat” or “Normal”. This option is used to set the play mode of 3 tracks played at the scheduled time.
- Select the “OK” button to apply setting and exit from the MP3 timer setting interface.

MP3 tracks set for each schedule are only available for the corresponding schedule. When the next schedule is executed, the system will execute the next schedule, of which setting will overwrite the MP3 setting of the previous schedule. If no MP3 is set for the next schedule, no MP3 is played for the next schedule.

5.1.7 Tuner timer setting:

Turn the digital wheel to highlight the “Tuner setting” option, and press it once to access the “Tuner timer setting” interface (as shown in Fig. 5-1-4) (**Next page**), where band and station can be selected.

- Highlight the content in the box following the “Band”, and then press down the wheel to show the  icon. Turn the wheel to select, and press it again to apply and exit. The “Station” option can be set in the same way.

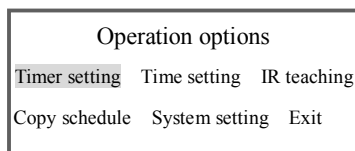

(Fig. 5-1)

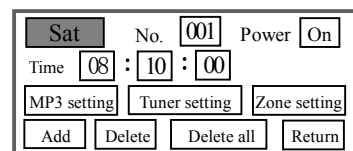

(Fig. 5-1-1)

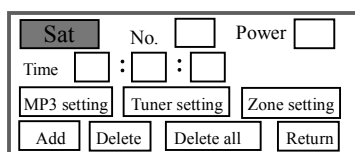

(Fig. 5-1-2)

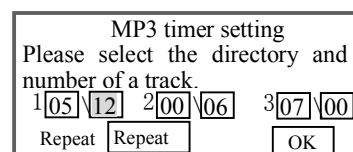

(Fig. 5-1-3)

Note: Select the “...” in the “Band” option to set as default setting, or select the “Stop” to stop the tuner at the scheduled time.

- Both AM and FM bands have up to 40 stations for selection, and the number refers to the storage number of a station. Stations tuned in to and stored to numbers during manual tuner operation can be called directly at the scheduled time.
- Select the “OK” button to apply and exit.

5.1.8 Zone setting:

Turn the digital wheel to highlight the “Zone setting” option, and press it once to access the “Zone timer setting” interface (as shown in Fig. 5-1-5), where a zone can be selected to set its volume and source.

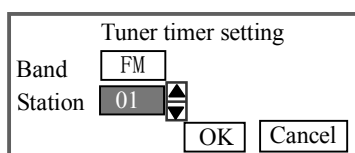

(Fig. 5-1-4)

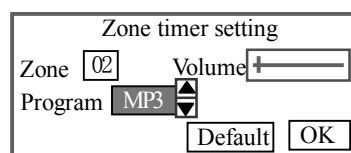

(Fig. 5-1-5)

- Selection of zone: Turn the digital wheel to highlight the content in the box following the “Zone”, and then press down the wheel once to show the  icon. Turn the wheel to select, and press it again to apply and exit.
- Adjustment of volume: For details, refer to the “Adjustment of volume” section in page 5.
- Selection of source: Select the source in the same way as selection of zone. When the “...” is selected, the default setting is selected; when the “Off” is selected, the zone is off at the scheduled time. This operation is used for selection of up to 6 audio sources, and all zones can use one source or different sources. If setting as described in sections 5.1.6 or 5.1.7 in page 10 is not done when source MP3 player or tuner is selected, the zone is in mute mode at the scheduled time. If the MP3 or tuner is playing before the scheduled time, and no setting is done for MP3 or tuner in the schedule, the MP3 player or tuner will keep playing the program which is played before the scheduled time is reached.
- Default: If it is set as default setting, the audio source status of the schedule is the same as the one executed previously.
- Select the “OK” button after setting to apply and exit from the zone timer setting interface.

5.1.9 Delete: To delete an existing schedule.

5.1.10 Delete all: To delete all existing schedules of the day selected (e.g. Wed).

5.2 Time setting

Turn the digital wheel to highlight the “Time setting” option in the “Operation options” interface, and press it to access the “Time setting” interface (as shown in Fig. 5-2 in the next page). Turn the wheel to highlight the desired option, and then press it to show the  icon. Turn the wheel to

change the digit, and press it again to apply and exit. After setting other options, select the “OK” button to apply and exit from the time setting interface, or select the “Cancel” button to cancel the setting and exit.

5.3 IR teaching

- Turn the digital wheel to highlight the “IR teaching” option in the “Operation options” interface, and press it to access the “IR teaching” interface (as shown in Fig. 5-3-1). Turn the wheel to highlight the desired function key. For example, to teach the “Play” function of DVD, select the “Play” option first, aim the DVD IR remote controller at the system, and then press the “▶||” key (i.e. play/pause key), and the text “OK” will be shown after the “Play” option (as shown in Fig. 5-3-2), indicating that teaching of “Play” function is completed. Perform the same operation to teach the others.

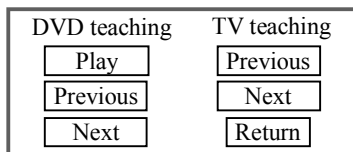

(Fig. 5-3-1)

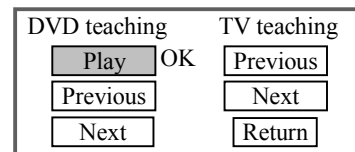

(Fig. 5-3-2)

- After teaching a function, direct operation can be performed to the function of DVD player or TV through a room controller by using the IR remote controller. For example, the “Play/Pause” function of DVD player can be executed directly in the DVD control interface of a room controller after teaching the DVD “Play” function.

5.4 Copy schedule

Turn the digital wheel to highlight the “Copy schedule” option in the “Operation options” interface, and press it to access the “Copy schedule” interface (as shown in Fig. 5-4), where all schedules of a weekday (e.g. Monday) can be copied to one weekday or more shown in the box . Operation is as follows:

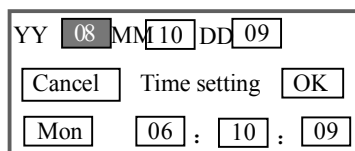

(Fig. 5-2)

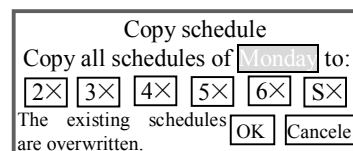

(Fig. 5-4)

- Turn the digital wheel to highlight the “Weekday” option and press it again, and a  icon will be shown. Turn the wheel to select a weekday, and press it again to apply and exit.
- Turn the digital to highlight the box “”, and press it, and the “X” will become “√” indicating that the weekday is selected. The “X” means that no copy is performed, and the “√” means that copy is performed.

- Select the “OK” button after operation to apply and exit from the interface, or select the “Cancel” button to cancel and exit.

5.5 System setting

Turn the digital wheel to highlight the “System setting” option in the “Operation options” interface, and press it to access the “IR teaching” interface (as shown in Fig. 5-5), where the backlight lighting status can be set (as “Auto” or “Always”). Operation is as follows:

- Turn the digital wheel to highlight the content in the box following the “Backlight”, and then press down the wheel once to show the  icon. Turn the wheel to select “Always” or “Auto”, and press it again to apply and exit. If it is set as “Auto”, the display will automatically turn off when no operation is performed within 20 seconds.
- Select the “OK” button to apply and exit.

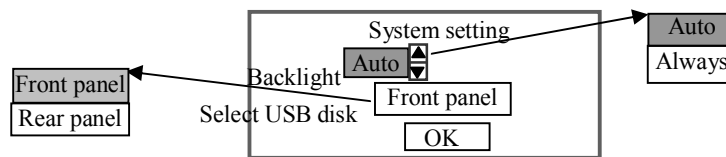

(Fig. 5-5)

- Select USB disk: This option is used to select a USB interface from the “Front panel” or “Rear panel”. If it is set as “Front panel”, tracks from the USB interface on the front panel will be played; if it is set as “Rear panel”, tracks from the USB interface on the rear panel will be played.

5.6 Operation of talk

To initiate a talk through the system, press and hold the “MIC” key and talk to the “MIC” pick-up. To end a talk, release the “MIC” key. Press and hold the “MIC” key, and the text “CALLING” will be shown on the interface. Release the “MIC” key, and the system will automatically return to the previous status.

※ Functions of IR Remote Controller

Tip: The IR remote controller is designed only for control of zone 1, MP3 player and tuner.

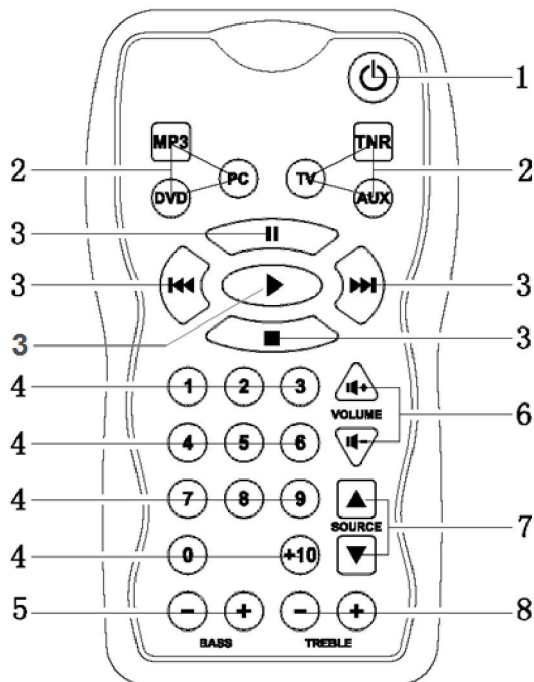

1. Zone on/off control key
2. Audio source selection key
3. Play status control key: Pause, stop, and previous or next track selection for MP3 mode, and stored station selection, mute and play for tuner mode.
4. Number keys: MP3 track selection key: Stored station selection key
5. Bass adjustment key
6. Volume control key
7. Source selection key
8. Treble adjustment key

When using the IR remote controller to control the MP3 or tuner, select the MP3 or tuner first, and then press any operation key or number key to access the operation interface of the source status. Press one of the selection keys of six sources or the “SOURCE” key when any display status is shown to return to the main interface. Press any volume or tone control key when any display status is shown to access the zone 1 control interface. Press the “TUNER” key when the system is in tuner status to switch between AM and FM bands.

Diagram of receiving angle of IR remote controller

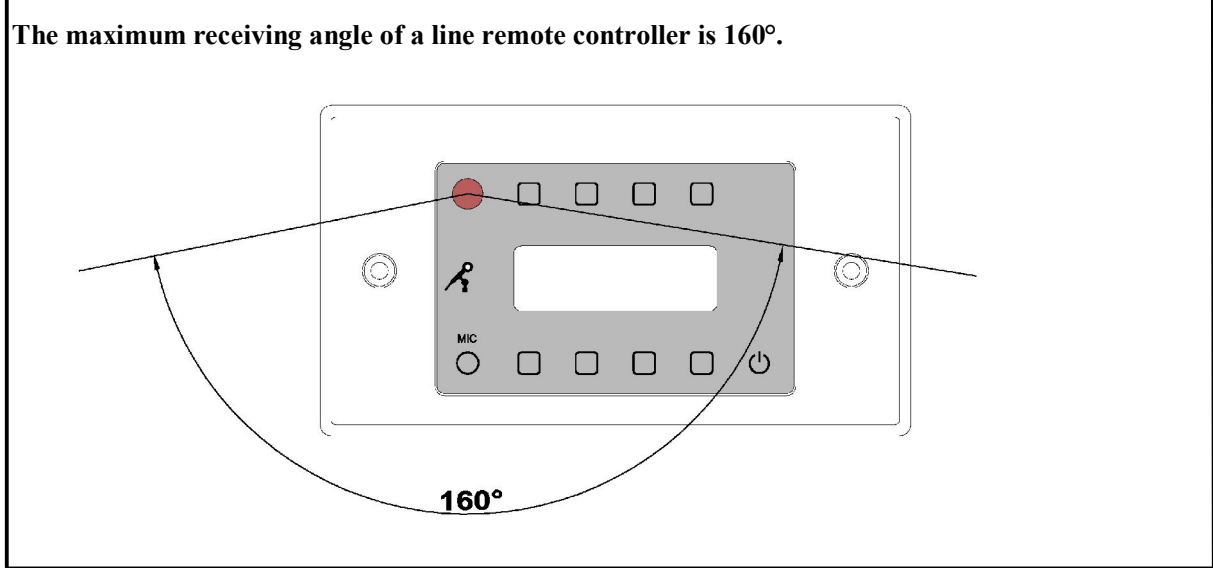
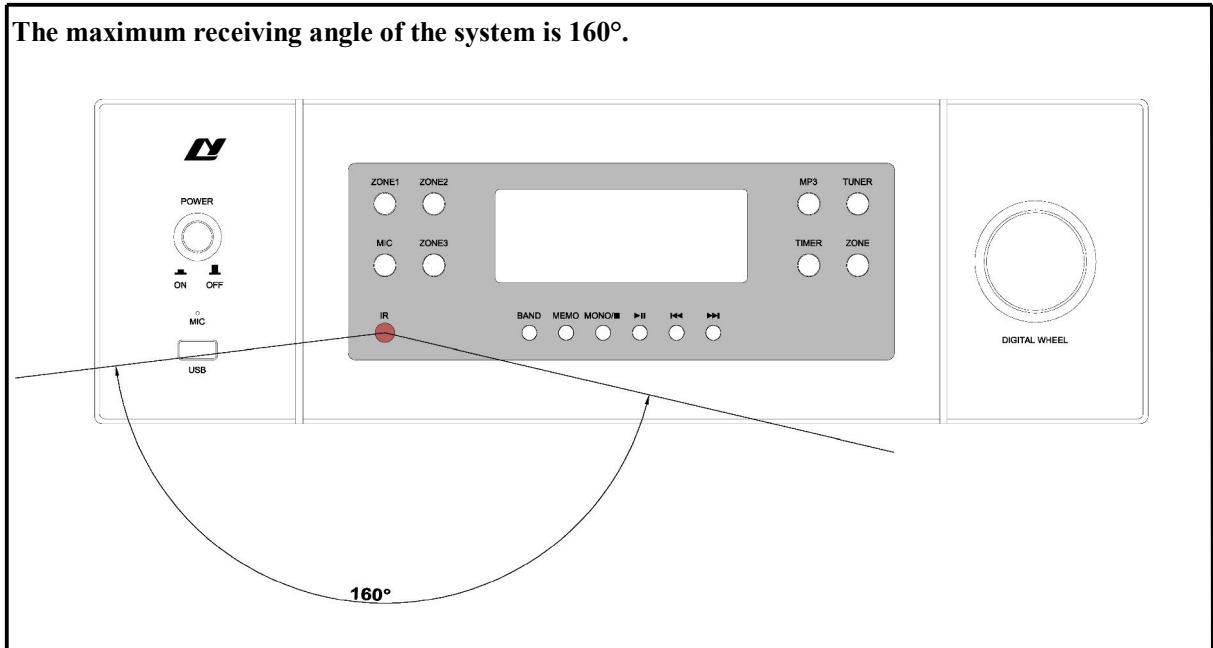

※ Application of File Format of USB Disk

1. This system supports a USB disk, mobile HDD or USB card reader (hereinafter collectively referred to as the USB storage) utilizing a general USB interface. The maximum bit rate of an MP3 file is 320kbps. Audio files in non-MP3 format cannot be played. In case that a track cannot be played, check whether it is as specified.
2. Supports FAT12, FAT16 and FAT32 file system.
3. To improve the operation speed and optimize management, it is recommended that the USB disk or mobile HDD used only store MP3 files other than files in other format, so as to facilitate the access of files and schedule programming.
4. Up to 99 primary directories can be created in the root directory, in each of which up to 99 tracks can be stored. Also, up to 99 tracks can be stored in the root directory. It is not necessary to create a secondary directory in a primary directory; otherwise, tracks in the secondary directory cannot be read. Tracks can be stored in a USB disk by three methods as follows:
 - Create no directory, and store all tracks in the root directory. This method facilitates track selection, but only 99 tracks can be stored. Note: To select a track in the root directory, the directory number should be set as “00”, e.g. 00 \ 03.

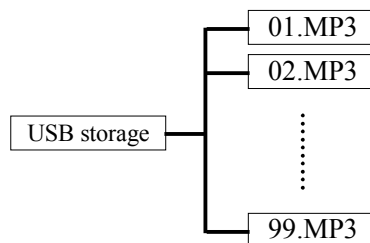

- Store all tracks in primary directories. By this method, tracks can be stored by classification, and up to 99x99 tracks can be stored.

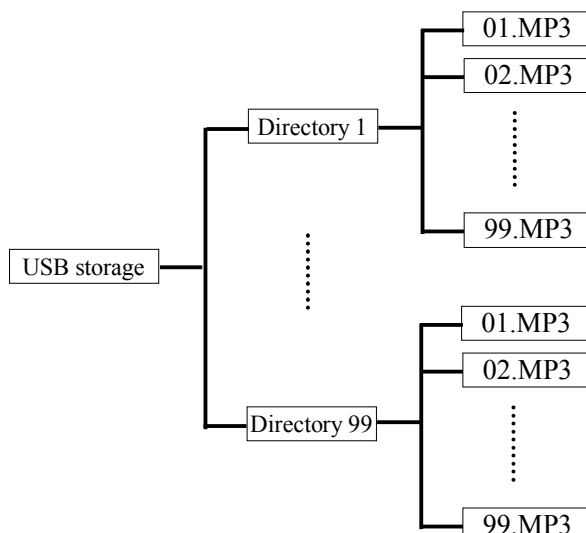

- Store tracks in root and primary directories. Up to 99+99x99 tracks can be stored.

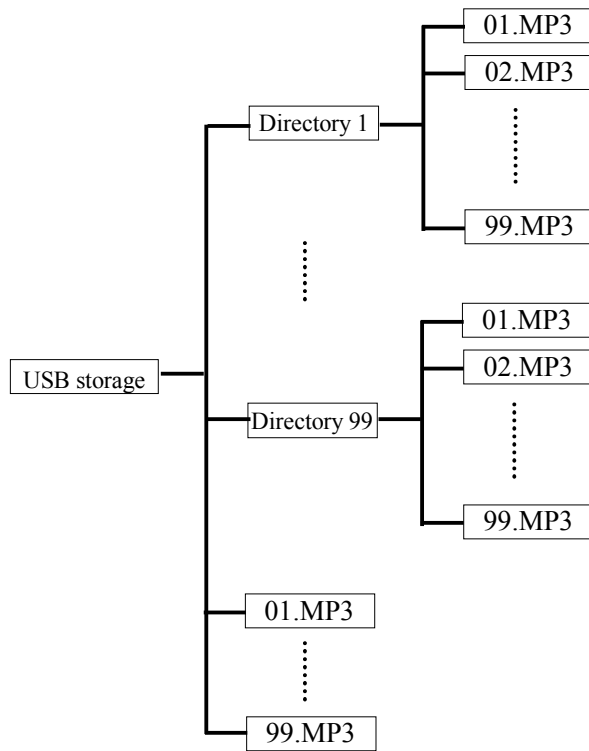

※ Precautions

1. Safety Precautions

- Disconnect the power plug of the system from the mains before wiring the system.
- Ensure that the input voltage to the system is as specified to avoid a risk of damage to the system.
- Never open the casing of the system to avoid electric shock from inside.
- Always disconnect the power plug from the mains when the system is not used, because the system is not disconnected from the mains even when the power switch is turned to the off position.
- Do not leave the system in a too hot or too cold place.
- Keep the system well ventilated to avoid damage to the system due to excessively high temperature.
- Disconnect the power plug if the air is moist or the system is not used for a long period.
- Remove the power plug from the outlet to disconnect the system from the mains before removing or reinstalling any part, or disconnecting or reconnecting any plug or cable.
- Do not open the casing for maintenance by yourself or unauthorized personnel in case of failure, so as to avoid an accident or further damage.
- Never place any corrosive on or near the system.

2. After-sales Service Precautions

- We will provide a three-year charge-free warranty (including replacement of parts) from the date when you purchase provided that the product is installed and operated as specified.
- The user should show the warranty card copy kept by the user and the sales invoice for repair.
- The warranty is invalid in the cases as follows:
 - (1) The product is damaged due to wrong installation, operation or handling.
 - (2) The product is damaged due to abnormal situations (e.g. excessively high mains voltage or ambient humidity).
 - (3) The product is damaged due to disasters and accidents.
 - (4) The ID number on the product body is changed, modified or removed.
 - (5) The product is repaired or modified by unauthorized personnel.

- Please store the manual and warrant card well.
- For problems or precautions not referred in this manual, please contact our distributor or visit our site at <http://www.lyintlcorp.com/>
- Please contact our technician (or distributor) in case of failure within the warranty period. We will take no responsibility in case that the product is disassembled or repair by unauthorized personnel.

※ Packing List

1 HS-6816 system, 1 pc. of power cord, 1 pc. of 1.5m-long cable with 2-2 RCA connectors, 1 FM antenna, 1 set of AM antenna and its base, 1 copy of User's Manual, 1 copy of certificate, 1 copy of warranty card, 1 HS-60R unit, 1 USB disk, 4 terminators, and 1 IR remote controller.

※ Specifications

1. MP3 Player

Item	Description
Format supported	MP3, at bit rate of <320kbps
Compatible storage	Compatible with most mobile storages utilizing USB interface.
Frequency response	20Hz-20KHz
THD	<0.2%

2. AM/FM Tuner

Item		Description
AM	Frequency range received	522-1620KHz
	Sensitivity	52dB μ
	S/N ratio	35dB
	Pass band	6kHz
	THD	0.2%
FM	Frequency range received	87.0MHz-108.0MHz
	Sensitivity	18dB μ
	S/N ratio	75dB for mono, and 70dB for stereo
	Pass band	15kHz
	THD	0.6%
	Stereo crosstalk	35dB

3. Timer

Item	Description
Programmable control power supply	1 channel (at mains voltage)
Socket capacity	220V, 2A
Time system	24-hour system
Numbers of programmable schedules	100 schedules, not repeated for a week.
Programmable options for a zone	a. Zone on/off b. Selection of audio source c. Volume control d. Treble and bass control e. MP3 player control f. AM/FM control

4. Comprehensive Specifications

Item		Description
Number of room controllers connected		Up to 32 controllers.
Number of zones		2 zones, each of which is provided with a 2-channel stereo power amplifier.
Room controller interface		Uses CAT-5 cables.
Audio specifications	Line input sensitivity	500mV±25mV
	Line input resistance	>10kΩ
	Zone output power	4X80W/8Ω
	Frequency response	20Hz-20kHz±0.5dB
	THD	Less than 0.2% at 1kHz and 1/3 rated output power.
	Tone control	Bass: ±10dB/100Hz Treble: ±10dB/10kHz
	S/N ratio	≥80dB
DC output voltage		40V±10%
DC output power		250W
Input power		AC220-240V/50-60Hz
Protection		AC220V/F8AL
Maximum power consumption		500W
Dimensions (L x W X H)		430×340×132mm
Weight		13kg

Specifications are subject to change without further notice.